

MPPA®-DEV4

Kalray's All-in-One Development Platform

APPLICATIONS



Data Centers



Autonomous Vehicles



Video Surveillance



Aerospace & Robotics



Industry 4.0



5G Telecom Infrastructure

KEY BENEFITS

A comprehensive & ready-to-use development platform

- Immediate execution of reference examples of acceleration use cases
- Included Kalray SDK and documentation for users to rapidly develop on MPPA®

MPPA® PCIe board included

- MPPA®3-80 Coolidge processor
- 2 x 100Gb Ethernet interfaces
- PCIe 16-lane interface
- 2 x 4GB DDR4 memory

Solution for any app acceleration with open APIs

- Standard programmability (C, C++, OpenCL)
- Open APIs
- POSIX with OpenMP support

High performance AI, low latency, low power

- 25 TOPS
- Multiple concurrent applications: Multi-CNN, computer vision, parallel pre/post processing ...
- Low power consumption
- Real-time data processing

MPPA®-DEV4 is a complete and ready-to-use environment to evaluate, develop and optimize applications on Kalray's MPPA®3-80 Coolidge™ processor.

The MPPA®-DEV4 includes all of the **hardware and software** needed for the development of your applications on the **MPPA® Coolidge processor** such as Deep Learning, Computer Vision, and Mathematical Algorithms.

The **AccessCore® Software Development Kit (SDK)** and **Kalray Acceleration Framework (KAF™)** are ideally suited for implementing or porting your applications to a standard x86-based Ubuntu Linux distribution and via KAF™, seamlessly assign these compute-intensive applications to the MPPA® Coolidge™ processor.

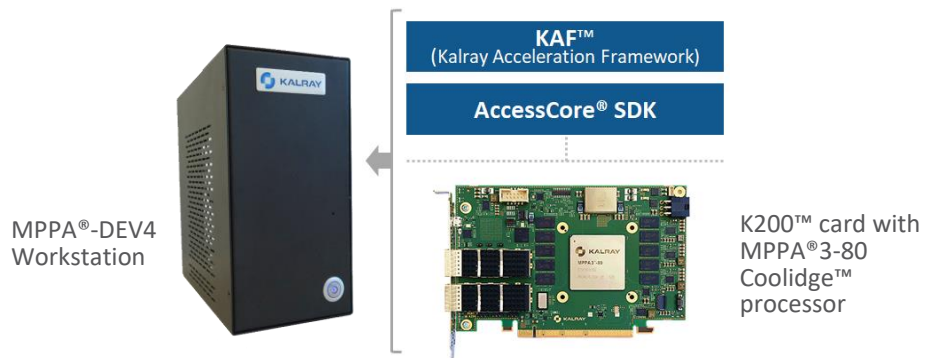

MPPA®-DEV4 Specifications

Hardware Specifications	
PCIe Board	K200™ card with Coolidge™ Processor
Debug and Trace	MPPA® probe card-K-DEBUG
Motherboard	Core i5 x86 Processor
Hard Drive	500GB
Memory	8GB DDR4 @2133 MT/s
Graphic	VGA / HDMI / DVI outputs
I/O	USB

Software Specifications	
Kalray AccessCore® Tool Chain	Kalray SDK and tool chain (running on x86)
Kalray AccessCore® Modules	MPPA® and Host Modules (libs, drivers, middleware)
KAF™	Kalray Acceleration Framework : Programming models environment for deployment on MPPA®
KaNN™	Kalray Neural Network: DL Compiler and DL runtime for typical Frameworks and Networks
Application specific Libraries	Optimized Computer Vision, Mathematical libraries for MPPA®
Ubuntu Linux Distribution	Running on x86

For illustration. Final products may vary.



■ AccessCore® SDK, a comprehensive software tool suite

Kalray's AccessCore® Software Development Kit (SDK) provides users with a set of tools and libraries that are optimized for making development of applications straight forward and for achieving the highest possible performance that the MPPA® Coolidge™ parallel architecture can offer.

AccessCore® SDK includes standard GNU C/C++ and LLVM compilers and a set of tools for code generation, debug and optimization, as well as Kalray Acceleration Framework (KAF™), for facilitating applications deployment.

With the AccessCore® SDK, the MPPA®-DEV4 can be used in two different modes: acceleration or standalone configurations.

■ Acceleration Configuration

In this configuration, the MPPA®-DEV4 allows users to accelerate their existing applications: using the Kalray Acceleration Framework (KAF™) that exposes standard APIs, users can easily offload most compute intensive functions on the MPPA®. Users can either use existing optimized MPPA® libraries or develop their own C/C++/OpenCL algorithms. KAF Framework will manage all the plumbing and make the data processing management straight forward.

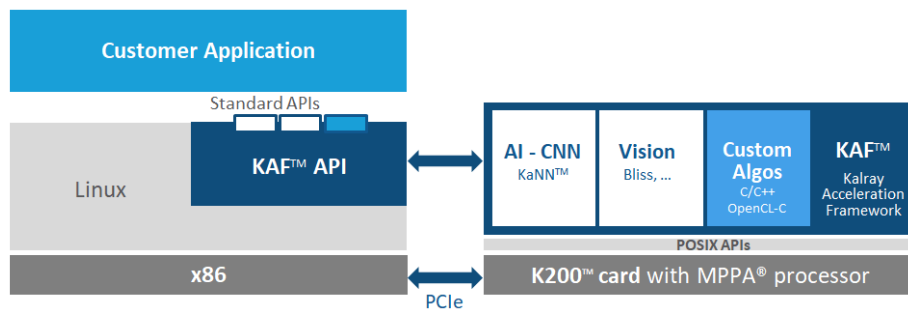

■ Standalone Configuration

In this case, the user's application is executed on the MPPA® processor alone: one of the MPPA® processor clusters is used as a Host and execute the main application, while other clusters are used to accelerate multiple compute intensive applications.

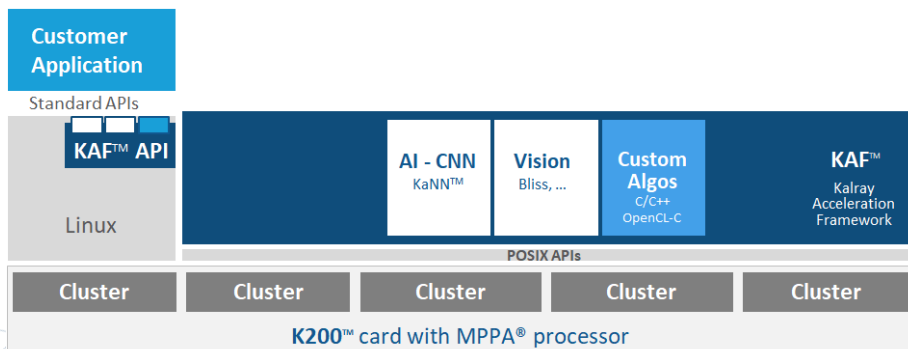

Why MPPA® is key?

The Massively Parallel Processor Array (MPPA®) is Kalray's ground-breaking manycore technology, giving chips more processing power with less power consumption.

Per Manycore MPPA® Processor

- 5 compute clusters
- 80 CPU cores and 80 co-processors
- From 600 to 1200 MHz frequency modes
- Data Broadcast support
- Support for multi-MPPA®

Per Compute Cluster

- 16 CPU 64-bit cores
- 16 AI Co-processors
- 1 Safety/Security 64-bit core
- Configurable L1 cache coherency
- 4 MB memory
- Direct access to DDR
- OS support (Linux and others)

AccessCore® SDK

AccessCore® SDK includes application specific libraries and tools such as:

- KaNN™ (Kalray Neural Network) for Machine Learning Inference
- KCV for Computer Vision
- Maths for Blas, Lapack or Eigen
- OpenSSL for Security and Cryptography
- C/C++/OpenCL programming
- It also provides a set of reference application examples, tutorials and optimized functions to facilitate the design of complex applications:
 - > Kalray Documentation Center
 - > Getting Started Tutorial

AccessCore® SDK supports multiple configurations of MPPA® processor.



■ Learn more:

contact@kalrayinc.com
www.kalrayinc.com

Copyright © 2020 Kalray -Not contractually binding.

